

6F21

Common rail diesel engine, 2-stage turbocharging

Number of cylinders	6
Bore and stroke (mm)	127 X 165
Total displacement (L)	6
Engine rotation	counter clockwise
Idle speed	700
Flywheel	SAE 1
Flywheel housing	SAE 14"



Customer benefits

Most advanced Common Rail technology and high-end injection system (2200 bar), key to achieve strict emissions regulations and competitive performances.

Highly efficient turbochargers optimized to operate with high performance keeping fuel consumption under control.

Individual cylinder heads allowing easy maintenance.

Key components made of highly reliable materials.

Rated power - Fuel consumption

Duty	kW	HP	RPM	Fuel consumption			IMO	EPA
				Optimum value		Rated power		
				g/kWh	g/kWh			
P3	599	815	2300	202	220	155	II	-
P4	662	900	2300	201	223	174	II	-
P5	735	1000	2300	186	228	194	II	-

	P3	P4	P5
Application	Intermittent	Light	High performance
Engine load variations	Important	Very important	Important
Average Engine load factor	60%	60%	60%
Annual working time	1000-3000h	less than 1500h	500h
Time at full load	2h each 12h	1h each 12h	1h each 12h

Dimensions and dry weight (mm/kg)

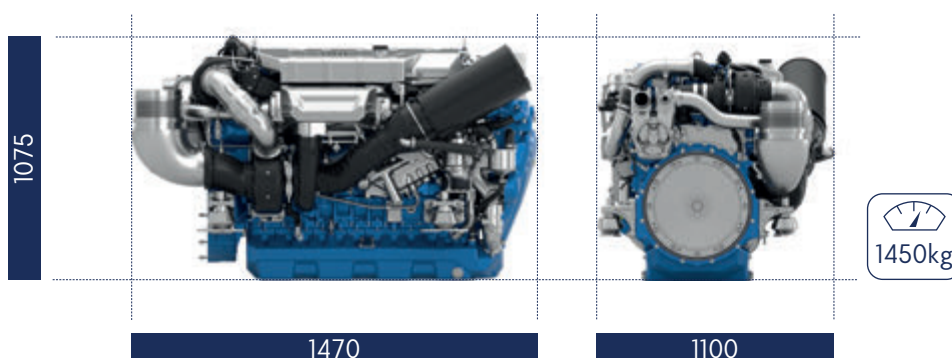

6F21

Performance

6F21 P5 735@2300 - Torque

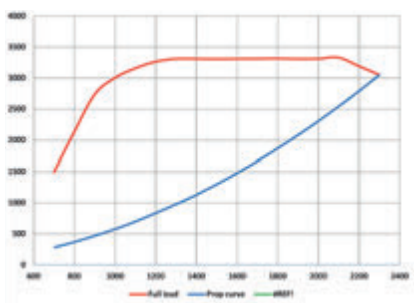

6F21 P4 662@2300 - Torque

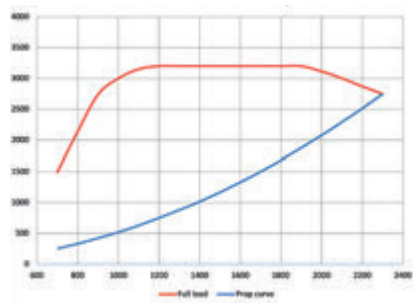

6F21 P3 588@2300 - Torque

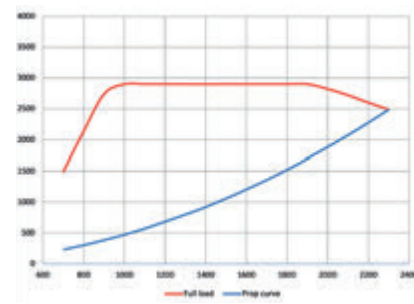

6F21 P5 735@2300 - Power

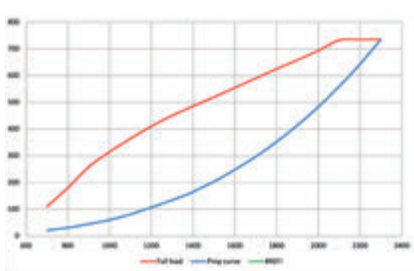

6F21 P4 662@2300 - Power

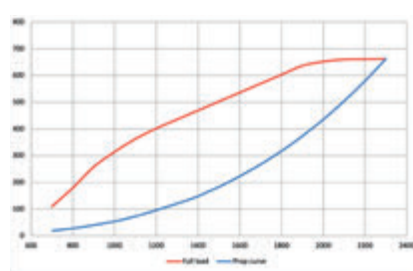

6F21 P3 588@2300 - Power

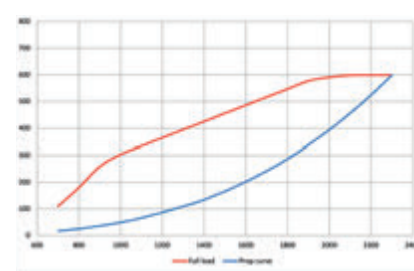

6F21 P5 735@2300 - BSFC (g/kWh)

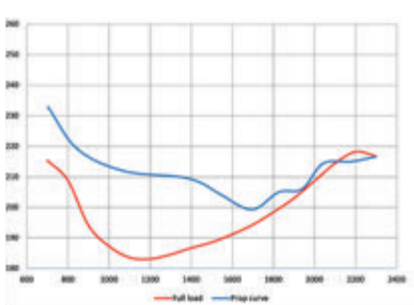

6F21 P4 662@2300 - BSFC (g/kWh)

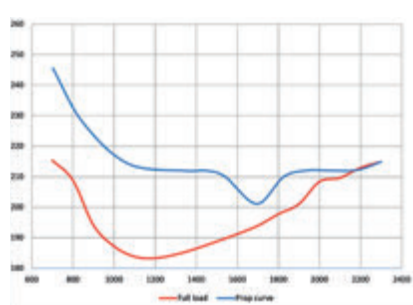

6F21 P3 588@2300 - BSFC (g/kWh)

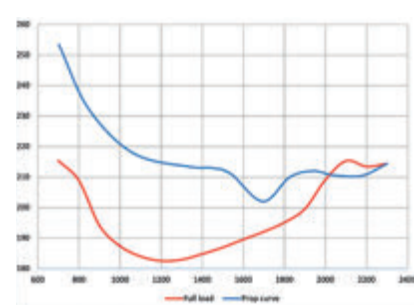

6F21 P5 735@2300 - BSFC (L/H)

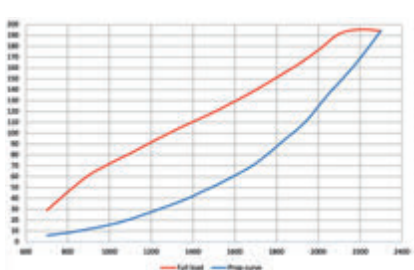

6F21 P4 662@2300 - BSFC (L/H)

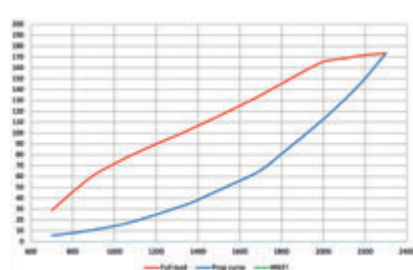

6F21 P3 588@2300 - BSFC (L/H)

